

SMD Type Power Inductor

TPRH1205-SERIES

1. Features

- 1.Magnetic Shielded surface mount inductor with high current rating.
- 2.Low resistance to keep power loss minimum.
- 3.The products contain no lead and also support lead-free soldering.



2. Dimension

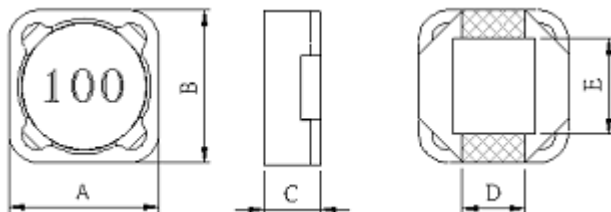

Series	A(mm)	B(mm)	C(mm)	D(mm)	E(mm)
TPRH1205	12.0±0.3	12.0±0.3	6.0 Max	5.0±0.2	7.6±0.2

Units: mm

3. Part Numbering

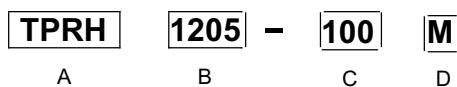

A: Series

B: Dimension A x C

C: Inductance 100=10uH

D: Inductance Tolerance M= ±20% , Y = ±30%

4.Specification

BULLWILL Part Number	Inductance (uH)		DCR (Ω) max.	Rated Current (A) max.
	Tolerance	Test Frequency (Hz)		
TPRH 1205-1R3Y	1.3±30%	1V/7.96M	0.012	8.00
TPRH1205-2R1Y	2.1±30%	1V/7.96M	0.014	7.00
TPRH1205-3R1Y	3.1±30%	1V/7.96M	0.017	6.00
TPRH1205-4R4Y	4.4±30%	1V/7.96M	0.020	5.00
TPRH1205-5R8Y	5.8±30%	1V/7.96M	0.021	4.40
TPRH1205-7R5Y	7.5±30%	1V/7.96M	0.024	4.20
TPRH1205-100M	10±20%	1V/1K	0.025	4.00
TPRH1205-120M	12±20%	1V/1K	0.027	3.50
TPRH1205-150M	15±20%	1V/1K	0.030	3.30

BULLWILL Part Number	Inductance (uH)		DCR (Ω) max	Rated Current (A) max..
	Tolerance	Test Frequency (Hz)		
TPRH1205-180M	18±20%	1V/1K	0.034	3.00
TPRH1205-220M	22±20%	1V/1K	0.036	2.80
TPRH1205-270M	27±20%	1V/1K	0.051	2.30
TPRH1205-330M	33±20%	1V/1K	0.057	2.10
TPRH1205-390M	39±20%	1V/1K	0.068	2.00
TPRH1205-470M	47±20%	1V/1K	0.075	1.80
TPRH1205-560M	56±20%	1V/1K	0.110	1.70
TPRH1205-680M	68±20%	1V/1K	0.120	1.50
TPRH1205-820M	82±20%	1V/1K	0.140	1.40
TPRH1205-101M	100±20%	1V/1K	0.16	1.30
TPRH1205-121M	120±20%	1V/1K	0.17	1.10
TPRH1205-151M	150±20%	1V/1K	0.23	1.00
TPRH1205-181M	180±20%	1V/1K	0.29	0.90
TPRH1205-221M	220±20%	1V/1K	0.40	0.80
TPRH1205-271M	270±20%	1V/1K	0.46	0.75
TPRH1205-331M	330±20%	1V/1K	0.51	0.68
TPRH1205-391M	390±20%	1V/1K	0.69	0.65
TPRH1205-471M	470±20%	1V/1K	0.77	0.58
TPRH1205-561M	560±20%	1V/1K	0.86	0.54
TPRH1205-681M	680±20%	1V/1K	1.20	0.48
TPRH1205-821M	820±20%	1V/1K	1.34	0.43
TPRH1205-102M	1000±20%	1V/1K	1.53	0.40

5. Material List

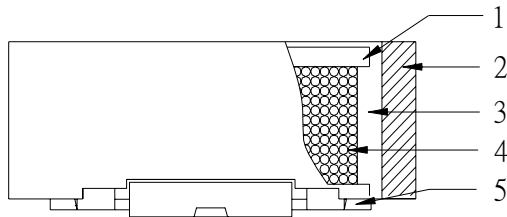

NO	ITEM	MATERIAL
1	CORE	FERRITE CORE (DR TYPE)
2	CORE	FERRITE CORE (RI TYPE)
3	GLUE	G500
4	WIRE	ENAMELLED COPPER WIRE
5	CLIP	SM212-032ET2N

6. Schematic Diagram

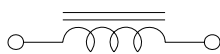

7. Reliability and Test Condition

Item	Performance	Test Condition
Operating Temperature	-40~+85°C	
Storage temperature	-40~+85°C	
Rated Current	Base on temp. rise & $\Delta L/LOA \leq 35\%$	
Temperature Rise Test	40°C typ. (Δt)	

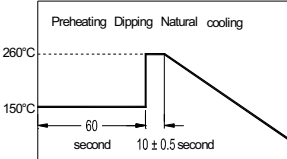
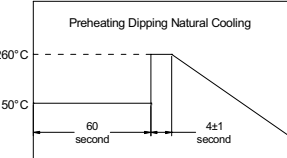
Item	Performance	Test Condition															
Solder heat Resistance	Appearance: No significant abnormality. Inductance change: Within $\pm 20\%$.	 <p>Preheat:150°C,60sec. Solder : D9930C (Lead-Free Solder) Solder temperature:260±5°C Flux: rosin Dip time:10±0.5sec.</p>															
Solderability	More than 90% of the terminal electrode should be covered with solder.	 <p>Preheat:150±25°C,60sec. Solder : D9930C (Lead-Free Solder) Solder temperature:260±5°C Flux: rosin Dip time:4±1sec.</p>															
Thermal shock	Appearance: no damage. Inductance: within±20%of initial value.	<table border="1" data-bbox="750 996 1045 1243"> <thead> <tr> <th>Phase</th> <th>Temperature(°C)</th> <th>Time(min)</th> </tr> </thead> <tbody> <tr> <td>1</td> <td>-25±2°C</td> <td>30±3</td> </tr> <tr> <td>2</td> <td>Room Temp.</td> <td>15</td> </tr> <tr> <td>3</td> <td>+85±2°C</td> <td>30±3</td> </tr> <tr> <td>4</td> <td>Room Temp.</td> <td>15</td> </tr> </tbody> </table> <p>Measured:50 times</p> <p>For TPRH Condition for 1 cycle Step1:-25±2°C 30±3 min. Step2:Room temperature 15 min. Step3:+85±2°C 30±3 min. Step4: Room temperature 15 min. Number of cycles:50</p>	Phase	Temperature(°C)	Time(min)	1	-25±2°C	30±3	2	Room Temp.	15	3	+85±2°C	30±3	4	Room Temp.	15
Phase	Temperature(°C)	Time(min)															
1	-25±2°C	30±3															
2	Room Temp.	15															
3	+85±2°C	30±3															
4	Room Temp.	15															
Humidity Resistance Test	Appearance: no damage. Inductance: within±20%of initial value.	<p>Temperature:40±2°C. Applied current:rated current. Duration:500 hrs. Humidity:90~95%</p>															
High Temperature Resistance Test	Appearance: no damage. Inductance: within±20%of initial value.	<p>Temperature:85±2°C. Applied current:rated current. Duration:500 hrs.</p>															

8. Recommended PC Board Pattern

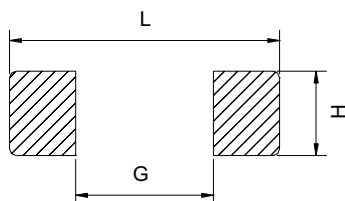

L(mm)	G(mm)	H(mm)
12.6	7.0	5.4

Reflow soldering Condition

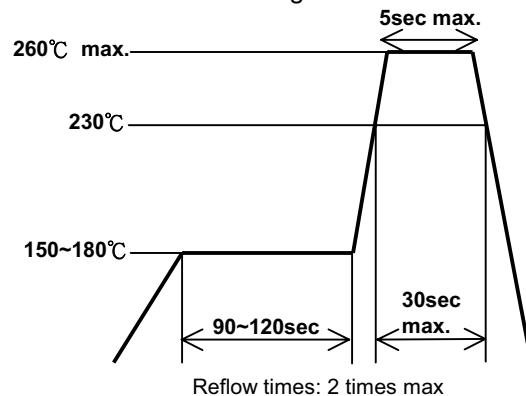

9.Packaging Information

9-1.Reel Dimension & Tape Dimension

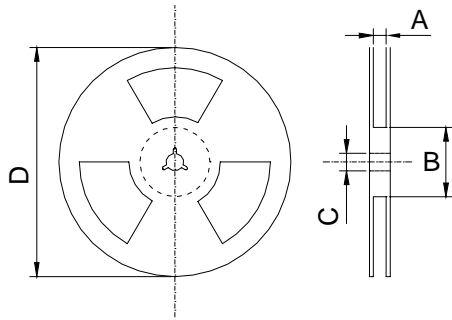

STYLE	A(mm)	B(mm)	C(mm)	D(mm)
13"X24mm	24.5±0.1	100±1	13.0±0.5	330

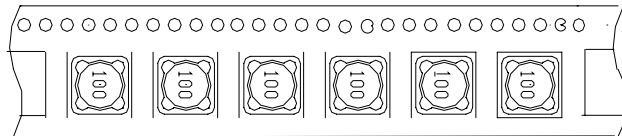

9-2.Packaging Quantity

SERIES	1 REEL	INNER CARTON			OUTER CARTON		
	Q'TY(PCS)	REEL	Q'TY(PCS)	SIZE(cm)	INNER	Q'TY(PCS)	SIZE(cm)
TPRH1205	500	2	1000	36X36X8	4	4000	38X38X33

9-3. Tearing Off Force

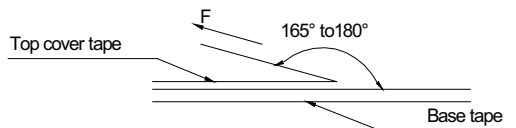

The force for tearing off cover tape is 12 to 130 grams in the arrow direction under the following conditions.

Room Temp. (°C)	Room Humidity (%)	Room atm (hPa)	Tearing Speed mm/min
5~35	45~85	860~1060	300

Application Notice

- Storage Conditions

To maintain the solderability of terminal electrodes:

1. Temperature and humidity conditions: Less than 40°C and 70% RH.
2. Recommended products should be used within 6 months form the time of delivery.
3. The packaging material should be kept where no chlorine or sulfur exists in the air.

- Transportation

- 1.Products should be handled with care to avoid damage or contamination from perspiration and skin oils.
2. The use of tweezers or vacuum pick up is strongly recommended for individual components.
3. Bulk handling should ensure that abrasion and mechanical shock are minimized.